

Electric Compressors



SANDEN

INNOVATING COMFORT

Future Comfort for Future Cars

The Road to Electrification

Electric compressors for niche hybrid and full electric vehicles, battery thermal managing and integrated parking cooling.

2024

Sanden will launch the 4th generation 800V - 45cc electric compressor.
Sanden will launch the 4th generation 48V - 33cc electric compressor.



2021

Sanden launched the 4th generation 470V - 33cc electric compressor.



2020

Sanden launched the 4th generation 470V - 45cc electric compressor.



2018

Sanden launched the first Gen2 Evo 48V - 33cc electric compressor into mass production.



2015

2015 - Sanden launched the 430V Gen2 Evo electric compressor.



2011

2011 - Sanden launched its first 430V - 33cc and 24V - 15cc.



2009

Sanden manufactured the first generation of electric compressors with an integrated inverter.



1997

Sanden began supplying the original electric compressor into mass production.



Drawing on the success of the first Sanden electrical compressor originally developed in 1990, the Sanden Gen2 Evo model features a new, more compact design and was developed to withstand tough operating conditions, guaranteeing a long service life.

Leading Sanden Technology

Sanden Gen2 Evo models have no start-up restrictions for quick acceleration, a smoother drive due to internal balancing and have been designed to have a low oil circulation throughout their operating range, which optimises their service life.

Low NVH

Due to an integrated muffler, the Gen2 Evo achieves a low noise emittance of >64dB at 5000 rpm.

Integrated Oil Separator

Sanden Gen2 Evo compressors feature an integrated oil separator, thereby minimising oil migration to the system and maximising lubrication to the compressor.

Sanden SHS33 Compressor



Next generation full electric semi hermetic compressor with integrated inverter

- 8kW cooling capability from 33cc displacement
- Maximum continuous RPM 8,000
- Suitable for R134a refrigerant and R1234yf refrigerant with Sanden SP-A2 oil
- Direct mount
- Available in 288v and 24v*, CAN or LIN software control
- Original equipment parts

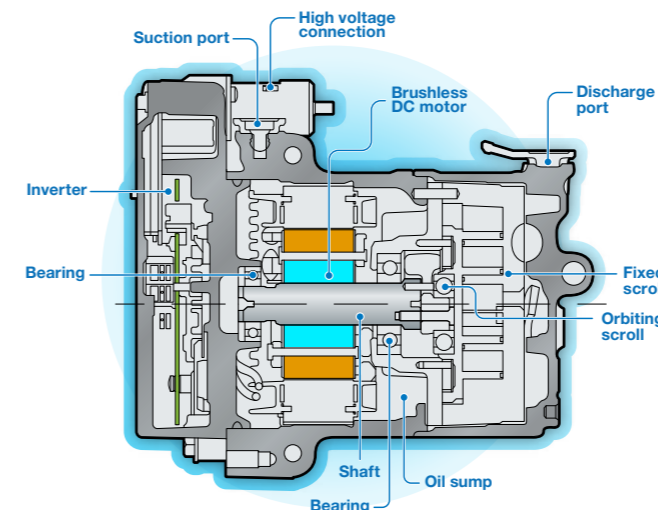

*24v model features 15cc displacement and 2.5kW cooling capability.

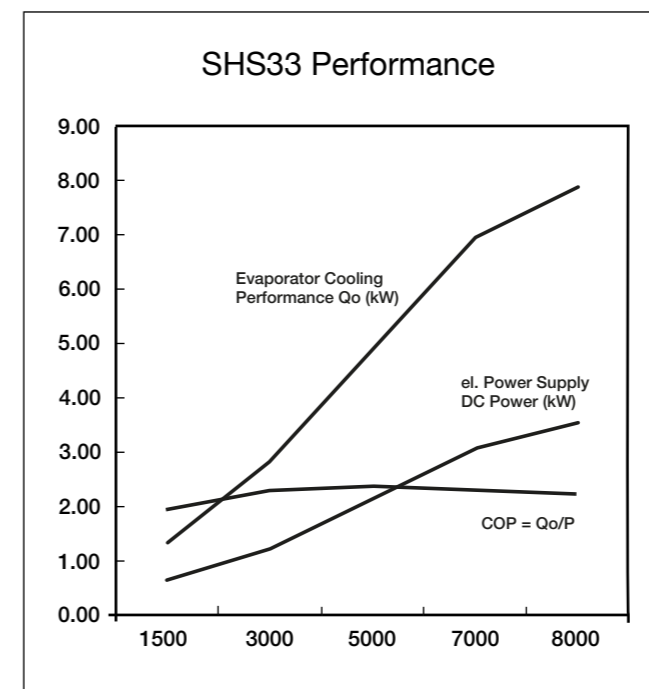

2nd Generation

The Sanden Gen2 Evo electric compressor is a general-purpose model that can be used for a wide range of heating and cooling operating conditions (e.g., heat pump systems).

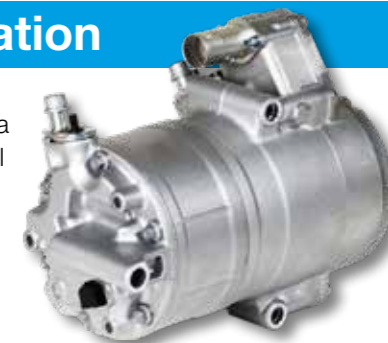

This type of electric compressor can be used on 24V electric trucks and 48V mild hybrid vehicles, and is widely available in the aftermarket.

Specifications

Discharge capacity	15cc	33cc	33cc
Voltage	24v	48v	260 - 432v

3rd Generation

3rd Generation is a compact, lightweight, and low noise model. This type of compressor can be used in a wide range of vehicles, including hybrid vehicles, electric vehicles, and fuel cell vehicles, and is offered mainly in Japan and China.

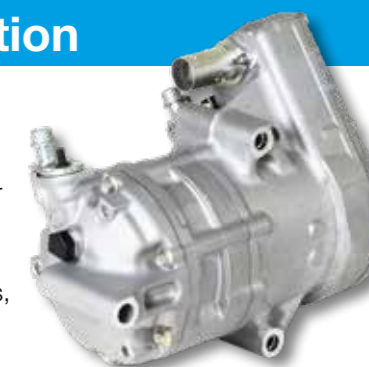

Specifications

Discharge capacity	27cc	33cc
Voltage	165 - 208v	210 - 470v

4th Generation

The Sanden 4th Generation electric compressor is a large-capacity, high-efficiency, and high-durability model adaptable to the integrated thermal management systems, and is widely available around the world.



Specifications

Discharge capacity	33cc	45cc
Voltage	48v	210 - 470v

Electric Compressor Performance



Future comfort. Future transport.

- Low NVH
- High volumetric efficiency
- Integrated oil separator
- Leading Sanden technology
- Compact inline concept

Sanden Generic Electrical Compressor 288V			
Part Number		3142	3143
Displacement		33cc	
Operational Speed	Min	700rpm	
	Max	8500rpm	
High Voltage Range (Operational Guarantee)	Min	165V	
	Max	432V	
Size		ø123mm L=235mm	
Weight		6.3kg	
Oil	Type	SP-A2	
	Amount	120g	
Cooling Performance		5.0kW*	
Communication		LIN	CAN

*5.0 Kw at rpm: 5000 Pd/Ps = 1.5/0.3 MPa SH/SC= 25/10 °K

Sanden Generic Electrical Compressor 24V		
Part Number		4199
Displacement		15cc
Operational Speed	Min	700rpm
	Max	5000rpm
High Voltage Range (Operational Guarantee)	Min	18V
	Max	32V
Size		ø123mm L=235mm
Weight		5.2kg
Oil	Type	SP-A2
	Amount	120g
Cooling Performance		2.78kW*
Communication		CAN

*2.78Kw at rpm: 4250 Pd/Ps = 1.1/0.4 MPa, SH/SC = 10/5°K

Sanden Generic Electrical Compressor 48V			
Part Number		3247	3248
Displacement		33cc	
Operational Speed	Min	700rpm	
	Max	8500rpm	
High Voltage Range (Operational Guarantee)	Min	24V	
	Max	54V	
Size		ø123mm L=235mm	
Weight		7.5kg	
Oil	Type	SP-A2	
	Amount	120g	
Cooling Performance		5.0kW*	
Communication		LIN	CAN

*5.0 Kw at rpm: 5000 Pd/Ps = 1.5/0.3 MPa SH/SC= 25/10 °K

Condensation capacity is key to improve the performances and reduce power consumption

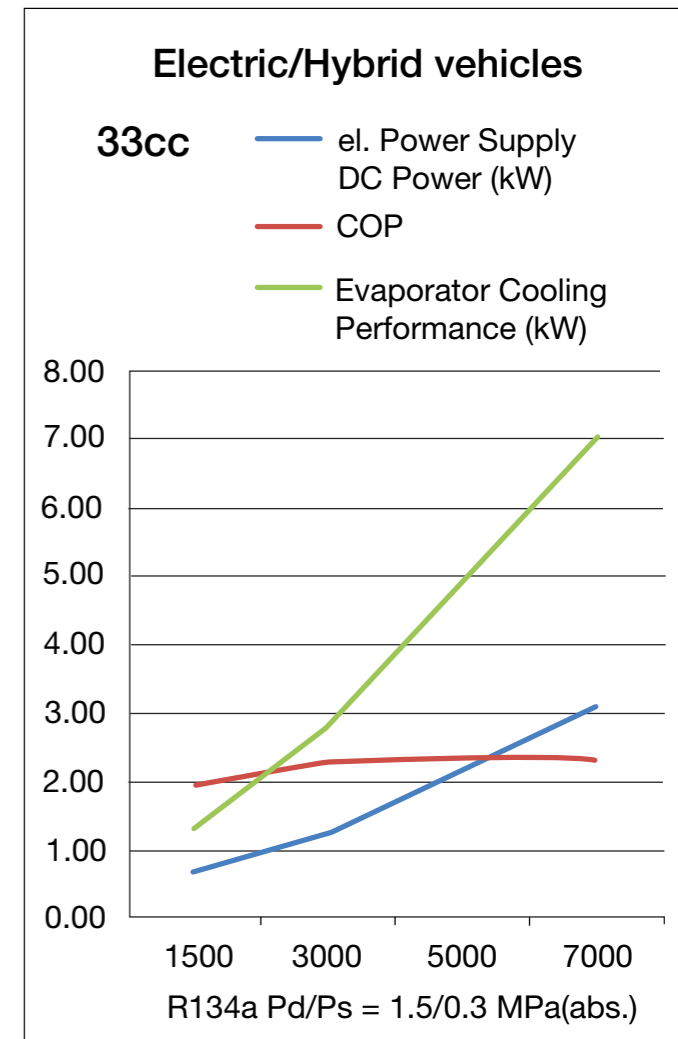
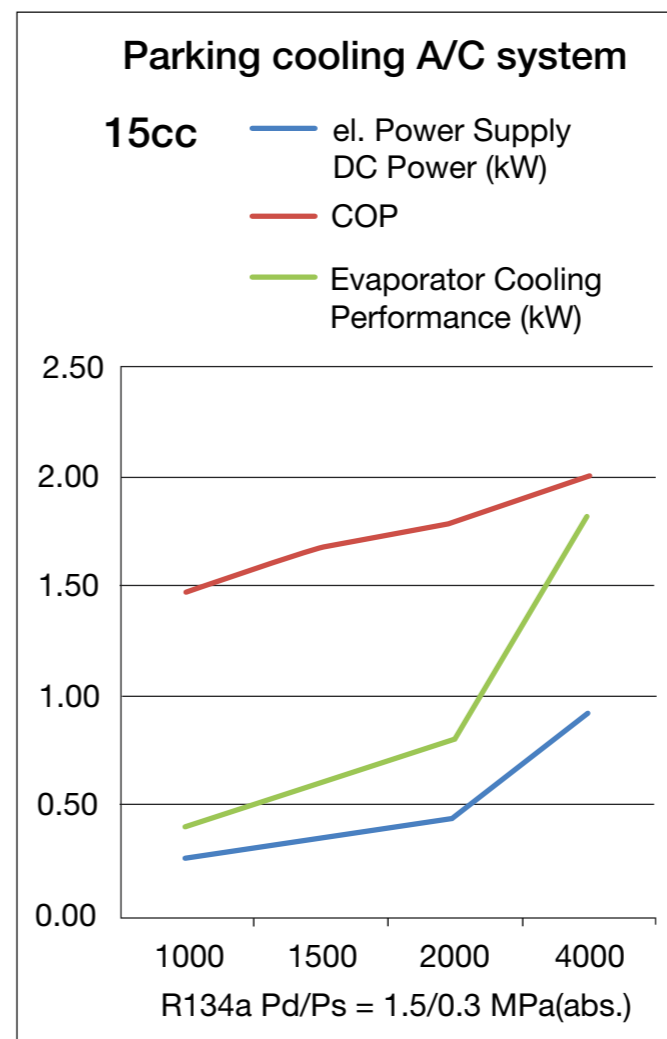
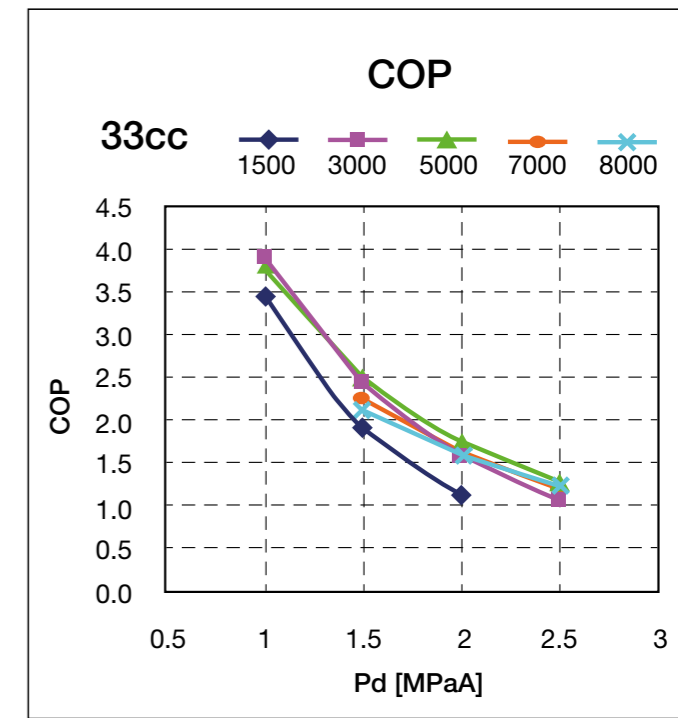
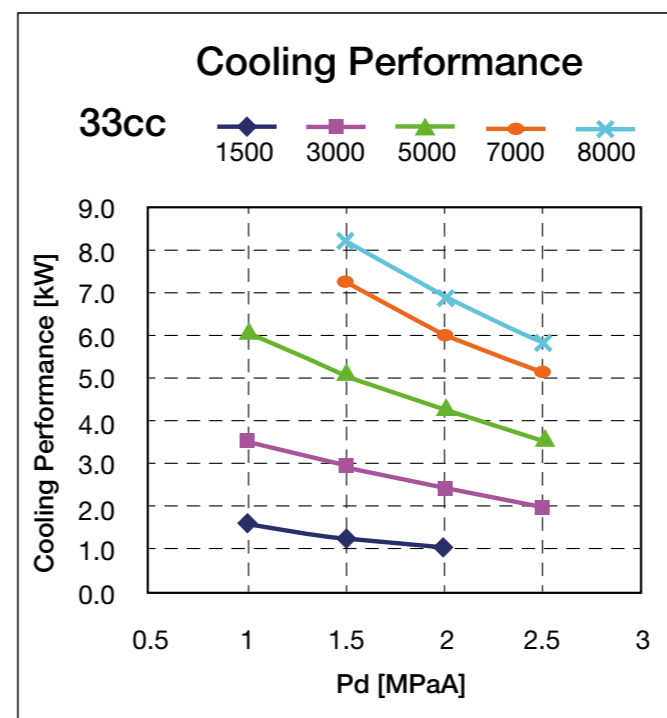

Electric Interface

HV Connector - Power

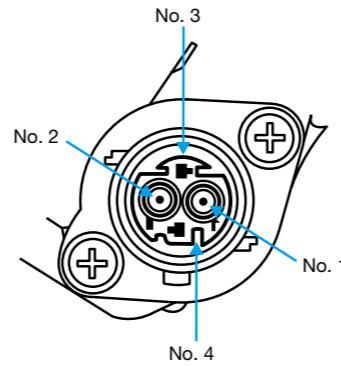
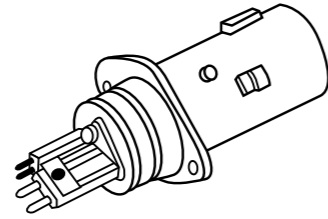
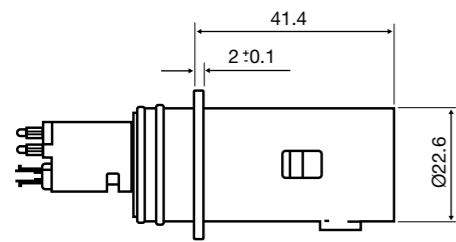

Pin No.	Assignment
1	HV+
2	HV-
3	Interlock B in connector
4	Interlock A in connector

Item	Detail
Supplier	Hirschmann Automotive GmbH
Harness part number	SK-14811-0
Part number compr. side	905-690-...60
Connector cycles	50 times plug/unplug

LV Connector - Control

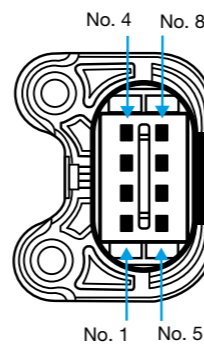
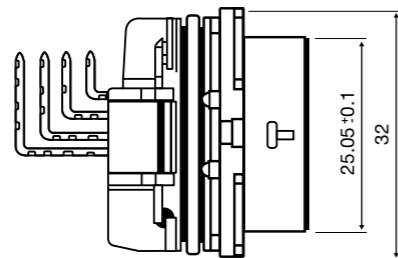
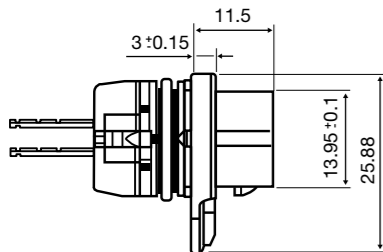

Pin No.	Assignment	
	CAN	LIN
1	LV+	LV+
2	Empty	LIN
3	LV-	LV-
4	CAN L	Empty
5	CAN H	Empty
6	Interlock A	Interlock A
7	Interlock B	Interlock B
8	Empty	Empty

Item	Detail
Supplier	Hirschmann Automotive GmbH
Harness part number	805-031-55
Part number compr. side	905-673-...00
Connector cycles	50 times plug/unplug

Electric compressor harnesses



High voltage harness



Low voltage harness

Conductor cross section	6mm ²
Conductor diameter	3.4mm ²
Conductor construction	84 x max 0.31mm Cu bare
Diameter of core	4.3mm - 0.3mm
Core arrangement	2 cores twisted
Inner sheath	Silicone
Inner diameter	9.7mm - 0.4mm

Screening	Braid of tinned copper wires Single wire max. 0.16mm Optical covering: Min 85% Angle of braid: approx 70° ALU-PEPT foil, metal side in contact with braid
Jacket material	Silicone
Outer diameter	12.8mm - 0.6mm
Conductor resistance	< 3.2mm Ohm/m
Screen resistance	< 6.1mm Ohm/m
Static	> 4xD (outer diameter)
Dynamic	> 8xD (outer diameter)

Ways to control the electric compressor

1. Laptop + CAN/LIN adapter

- Connection from computer to compressor using a module
- Software needed to "input" the program to the module
- Control files needed in LIN or CAN versions



Sanden can provide:

- LDF (LIN) and DBC (CAN) files
- CAN OE configurations for LIN and CAN HV and LV



2. Final stage. From vehicle ECU

- Direct connection from vehicle ECU to compressor
Software to program the modules
- LDF = LIN Description File
Ready and can be provided by Sanden
- DBC = Data Base CAN for CAN compressors
Ready and can be provided by Sanden



Electric Compressor Circuit

A/C system components

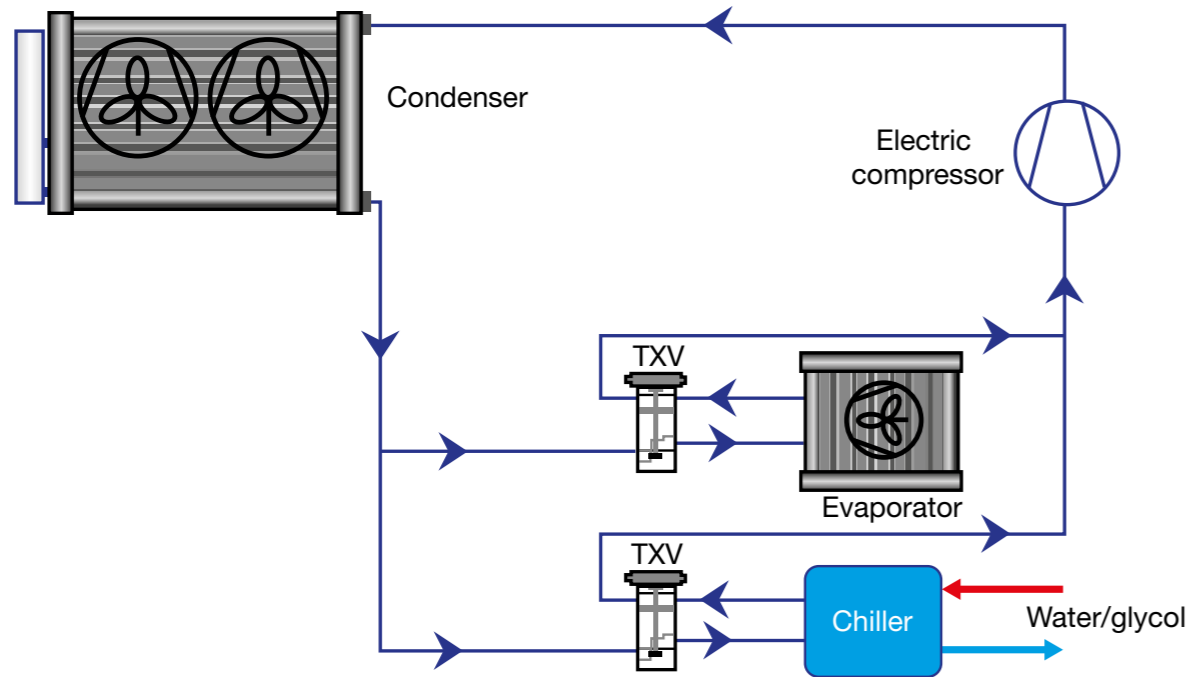

A/C system with integrated parking cooling

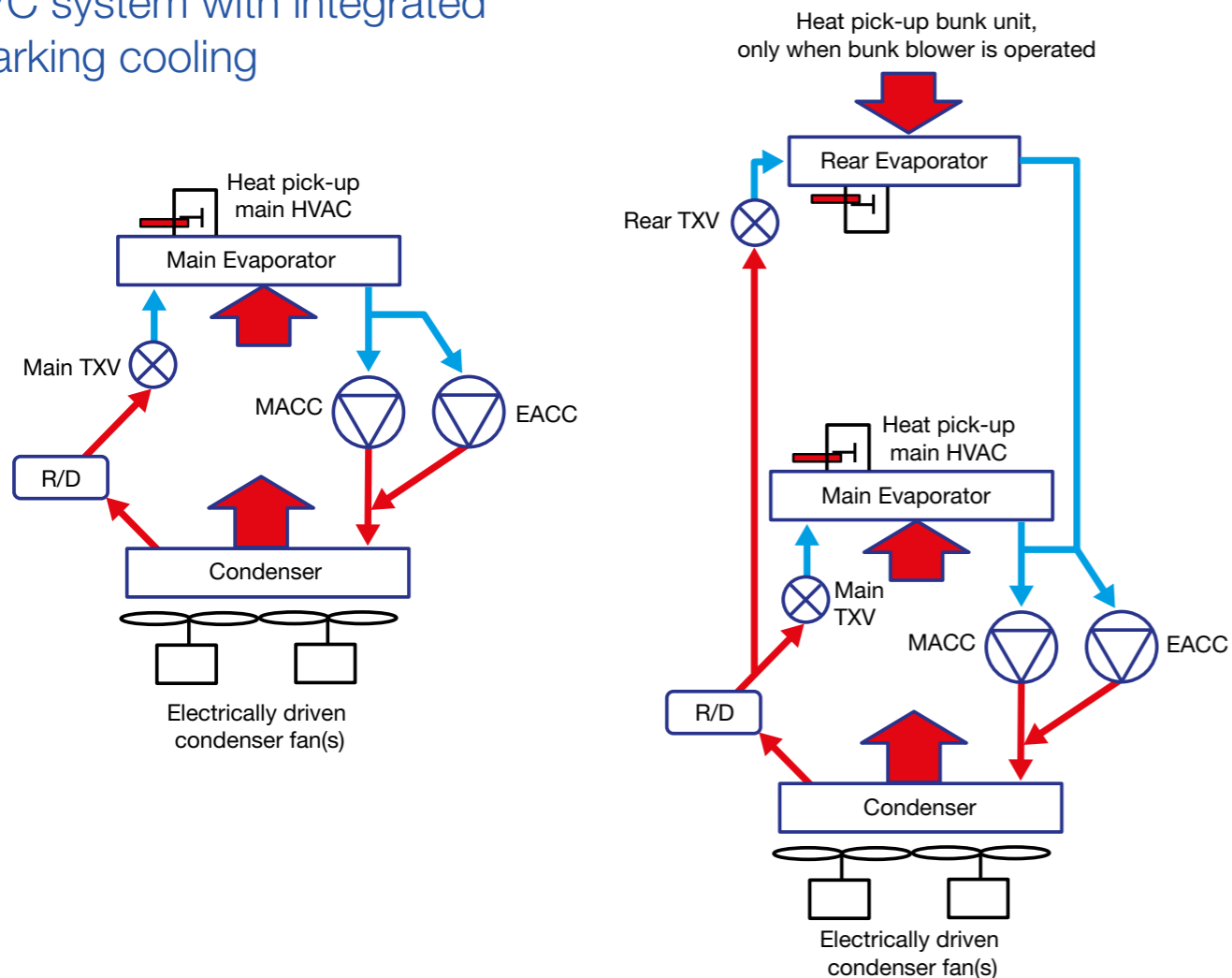

Sanden SP-A2 Oil

The introduction of the new refrigerant R1234yf and electric compressors has created the need to develop a new oil to ensure the optimal functioning of the new products without risk to the installer and the products.



Sanden has developed **SP-A2 oil** with the following goals:

- To be compatible with R134a and R1234yf refrigerants
- To be compatible with Sanden electric compressors
- To be compatible with all models and types of R134a Sanden compressors existing in the market
- To be compatible with the usual elastomers used in the A/C system

From now on, many more models will have SP-A2 oil instead of the traditional Sanden oils SP-10 or SP-15. If you receive the equivalent model for a compressor which used SP-10 or SP-15 oil and it has SP-A2 oil,

there will be no detrimental effect from the new oil regarding the proper functioning of the A/C system.

In reference to R134a refrigerant, a mixture of SP-10 and SP-A2 oils is allowed, providing both the oils are in a good condition (no particles, no humidity, no discolouration, etc).

The only Sanden approved oil for service of Sanden electric compressors is SP-A2.

The use of oils other than Sanden approved oils can lead to the rupture of the dielectric insulation in the case of Sanden electric high voltage compressors.

The consequence of poor electric insulation can be personal injury or even death due to electric shock.

Sanden now offers high quality wire harnesses to accompany Sanden electric compressors.

Associated Risks

High Voltage Electric Shock



HIGH VOLTAGE

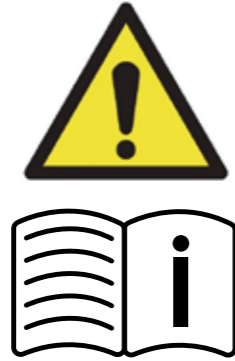

Capacitor discharge

Sanden compressors are equipped with auto discharge devices
($<60V$ after 5 seconds from U_{max})

Electromagnetic interferences can create malfunctioning of other electronic devices

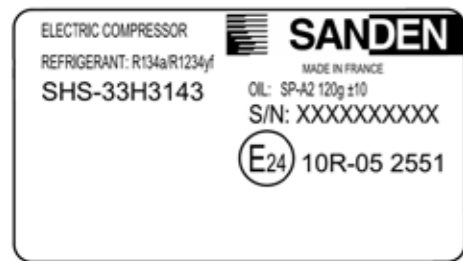

EMC Approved



Airbag malfunctioning

Electromagnetic compatibility. Sanden compressors are equipped with EMC filters

Water Jet: Do not spray directly on connectors



Electric Compressor Repair Precautions



Risks due to high voltage

Can cause serious personal injuries or death:

- Handling the compressor without proper training
- Handling the compressor connected to electric current
- Handling a damaged compressor
- Usage of the wrong compressor oil
- Usage of refrigerants other than those recommended by Sanden or contaminated refrigerants
- Any modification of the compressor or electric connections
- Handling the compressor with damaged harness/connectors
- Avoid the use of water jets on the compressor



Risks that can cause serious personal injuries or death:

- Refrigerant only must be manipulated by trained staff and authorised according to the regulations
- Use of other refrigerants than the recommended ones or contaminated refrigerants
- Air conditioning circuit only must be serviced with the use of proper personal safety equipment



Risks of component damage:

- The electric connectors are designed to be connected/disconnected a maximum of 50 times
- The presence of particles/humidity in the A/C system



Fire risks:

- Do not smoke during refrigerant manipulation, avoid the contact of oil/refrigerant with flames, sparks or hot surfaces

The manipulation of refrigerants must be done only by trained personnel who are in possession of the required permissions according to European or local applicable regulations.

About Sanden

Founded in 1943



Dynamo bicycle lamp

Sanden was first established as Sankyo Electric Company by Kaihei Ushikubo as a manufacturer of bicycle lamps, with a distinctive owl trademark.

1950s

Introducing refrigeration



Refrigerated showcase

Sankyo Electric produced an open-type refrigeration showcase for business use - the first of its kind in the industry.

1970s

Automotive air-conditioning



First generation compressor



Sankyo Electric entered a technical alliance with Mitchell Corporation, accessing the automotive market by producing compressors for passenger cars in 1970. With this new industry came a new corporate identity - **SANDEN**

1980s

Becoming a global enterprise

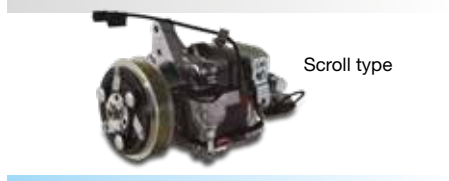

Scroll type

In 1981, Sanden developed the world's first scroll-type compressor for the automotive industry.

Sanden Vendo machine



Sanden acquired Vendo, creating sales and production bases worldwide, to become a truly global enterprise and industry leader.

1990s/2000s

Automotive industry leader

Electric type - original

Hybrid type



Drawing on the successes from strategic alliances that paved the way into the automotive industry, Sanden became known as a key compressor supplier for major OEMs.

Tackling environmental issues

Akagi Forest



Sanden developed open scroll-type automotive compressors to help prevent ozone layer destruction. For these environmentally friendly services, Sanden was awarded by the Agency for Natural Resources and Energy.

The first Swash Plate

Swash plate type



Sanden developed their first Swash Plate compressor for improved passenger car comfort. To meet emerging market needs, Sanden entered the heavy vehicle market and developed their first heavy duty and super heavy duty compressors.

2010s

Electrification



HVAC

Electric type - Gen1

Already an automotive market leader, Sanden developed a full electric compressor for use in passenger cars. Sanden became the market leader for truck integrated parking cooling and started to supply full HVAC assembly to key truck customers.

2018

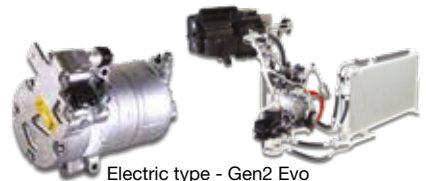

Electric type - Gen2 Evo

Sanden celebrated 75 years of business in 2018. With passionate, knowledgeable employees and innovative strategies, Sanden is committed to Delivering Excellence to every customer, every time.

2021

A new alliance



Sanden and Hisense entered into a new business alliance, and are working together to create a world-leading company in the fields of AI, battery thermal management and connected cars.

The Future

Stronger Together



Since the core values of Sanden and Hisense match, the two companies will work in synergy to create a better, more environmentally friendly future for the next generation.

Sanden International (Europe) GmbH

Rosewood, Chineham, Basingstoke RG24 8UT.

www.sandenaftermarket.com email: sie-aftermarket@g-sanden.com

SIEUK180062C